

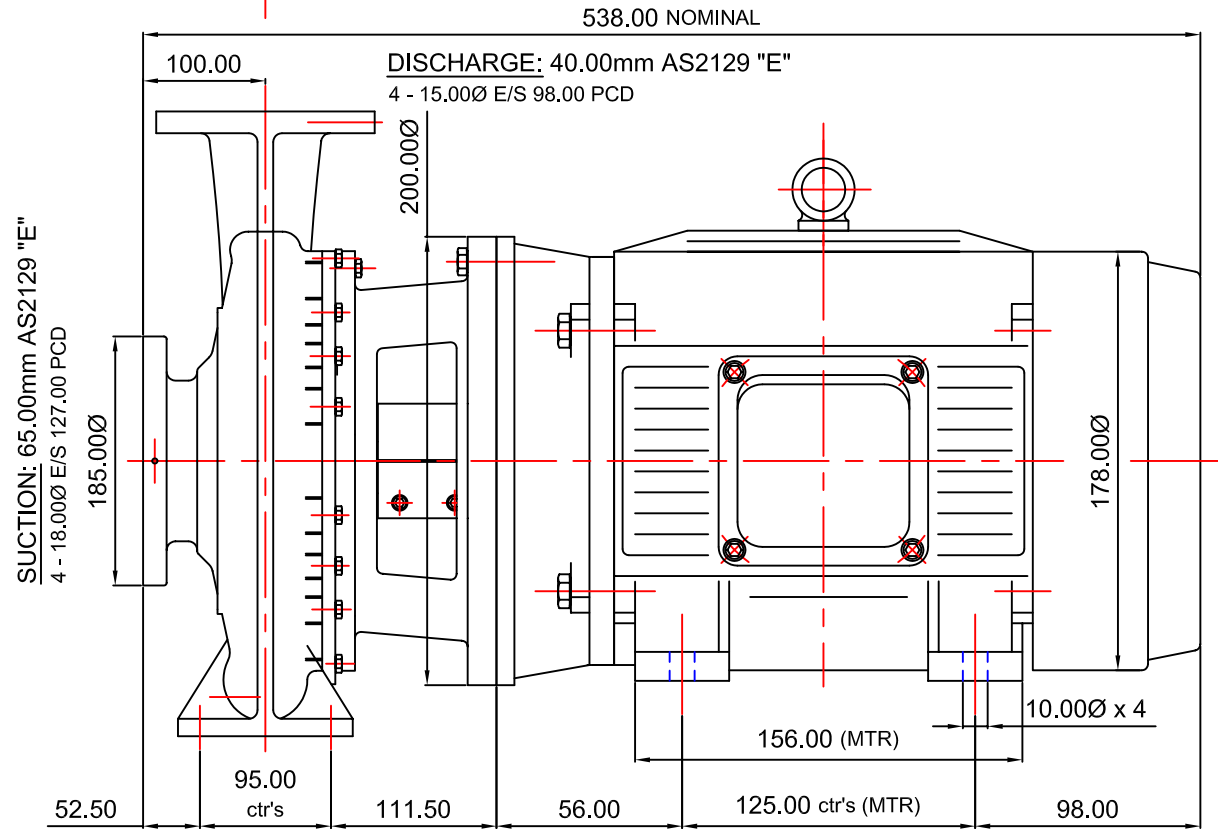
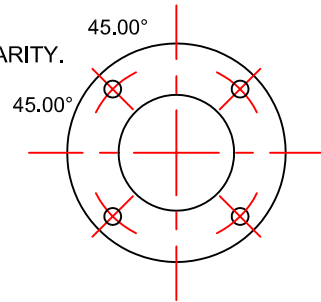
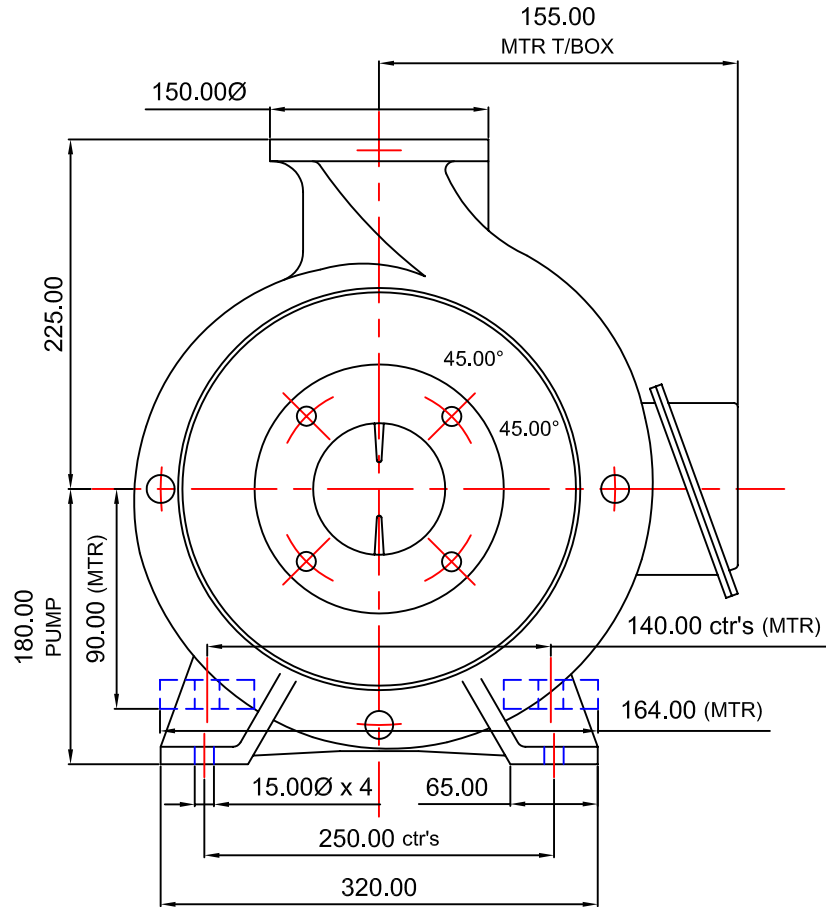

**STANDARD DETAIL NOTES:**

THIS IS A DIAGRAMMATIC REPRESENTATION AND CERTAIN DETAILS REMOVED FOR CLARITY.

**IMPORTANT:** ALL DIMENSIONS INDICATED ARE NOMINAL.

**IMPORTANT:**  
THIS DATA IS RELEASED FOR  
REFERENCE ONLY.



REVISION	THIS DATA REMAINS THE PROPERTY OF STALKER ENGINEERING. NO DATA MAY BE REPRODUCED WITHOUT PRIOR CONSENT OF COMPANY. DATA MAY BE ALTERED WITHOUT NOTIFICATION.	<b>GENERAL TOLERANCES</b> METRIC +/-0.400mm IMPERIAL +/-0.015"		DRWN: AR	 <b>STALKER PUMPS</b> <a href="http://www.stalkerpumps.com.au">www.stalkerpumps.com.au</a> DIMENSION OUTLINE DIAGRAMMATIC ISO2858 65/40-250 CC SERIES 1.5kW 4P 90L (EM033 MODULE 2)
	AS1100 3rd ANGLE PROJECTION	REFERENCE:		DATE: 17/07/2006	
	<b>DO NOT SCALE</b>	APPRVD:	CHECKED:	SCALE: DIAGRAMMATIC	
			FILE REF: REFER DWG NUMBER	DRAWING No: <b>2900ISOCCEM033DIMA3</b>	<b>A3</b>