

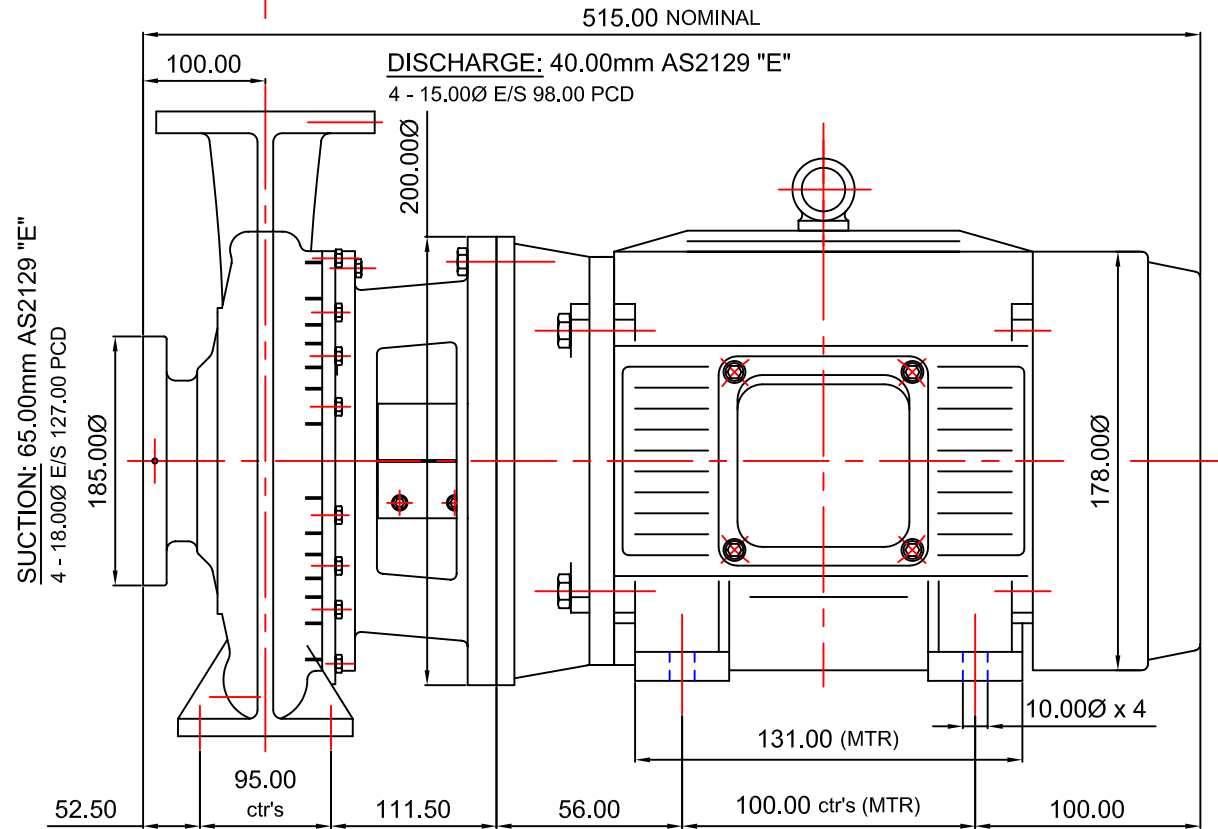
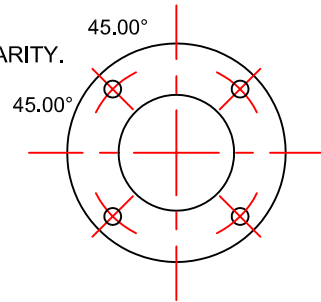
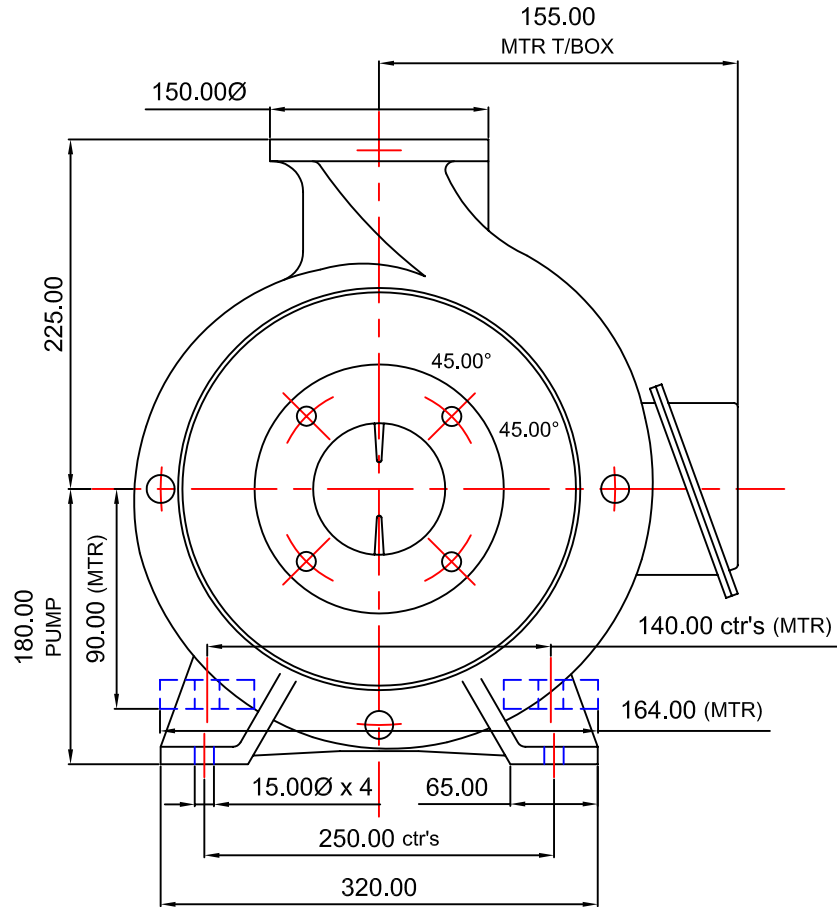

STANDARD DETAIL NOTES:

THIS IS A DIAGRAMMATIC REPRESENTATION AND CERTAIN DETAILS REMOVED FOR CLARITY.

IMPORTANT: ALL DIMENSIONS INDICATED ARE NOMINAL.

IMPORTANT:
THIS DATA IS RELEASED FOR
REFERENCE ONLY.



REVISION	THIS DATA REMAINS THE PROPERTY OF STALKER ENGINEERING. NO DATA MAY BE REPRODUCED WITHOUT PRIOR CONSENT OF COMPANY. DATA MAY BE ALTERED WITHOUT NOTIFICATION.	GENERAL TOLERANCES METRIC +/-0.400mm IMPERIAL +/-0.015"		DRWN: AR	 STALKER PUMPS www.stalkerpumps.com.au	
	AS1100 3rd ANGLE PROJECTION	REFERENCE:	DATE: 17/07/2006	DIMENSION OUTLINE DIAGRAMMATIC ISO2858 65/40-250 CC SERIES 1.1kW 4P 90S (EM032 MODULE 2)		
	DO NOT SCALE	APPRVD:	CHECKED:	SCALE: DIAGRAMMATIC	FILE REF: REFER DWG NUMBER	DRAWING No: 2900ISOCCEM032DIMA3