

STANDARD DETAIL NOTES:

THIS IS A DIAGRAMMATIC REPRESENTATION AND CERTAIN DETAILS REMOVED FOR CLARITY.

IMPORTANT: ALL DIMENSIONS INDICATED ARE NOMINAL.

IMPORTANT:
THIS DATA IS RELEASED FOR
REFERENCE ONLY.

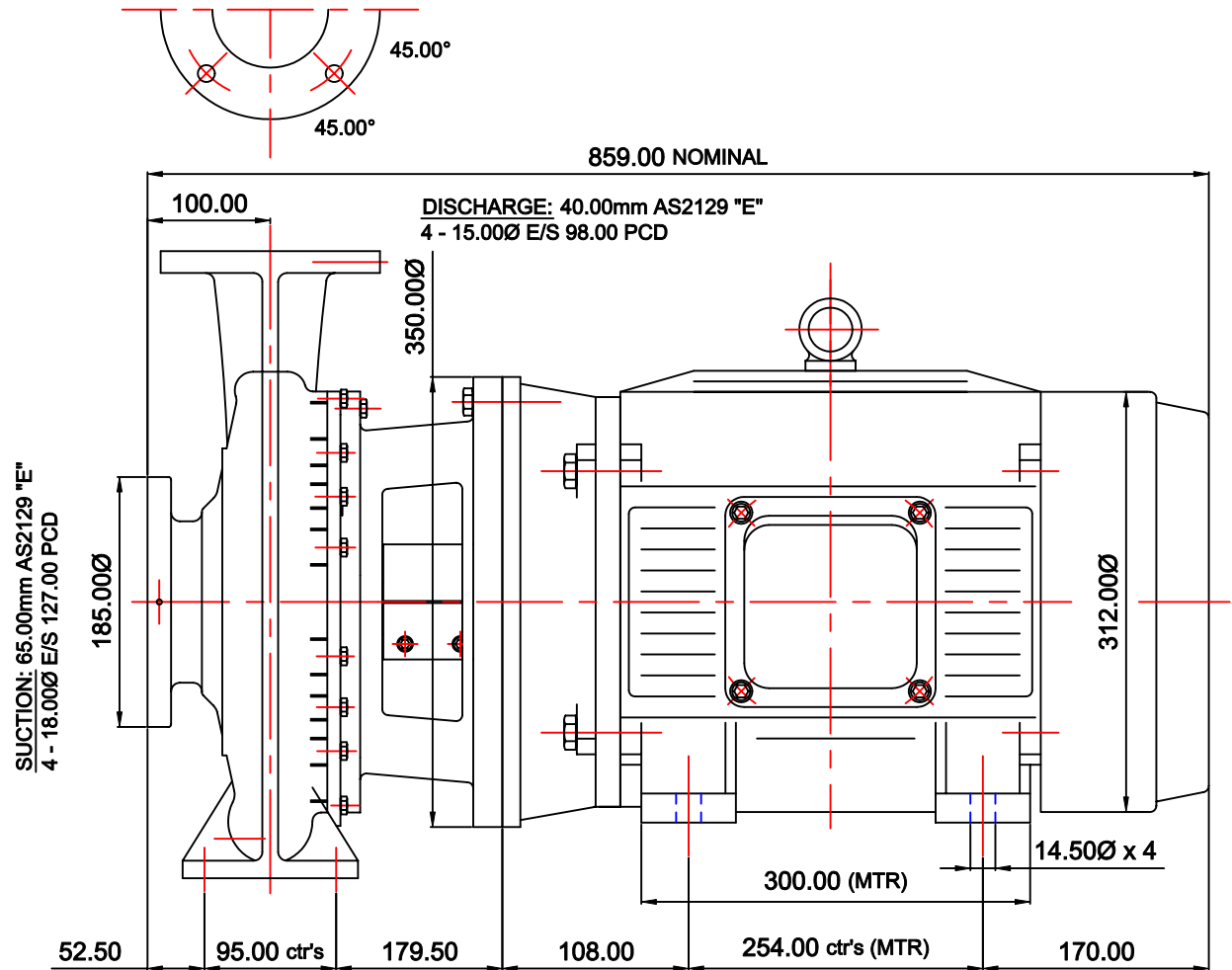
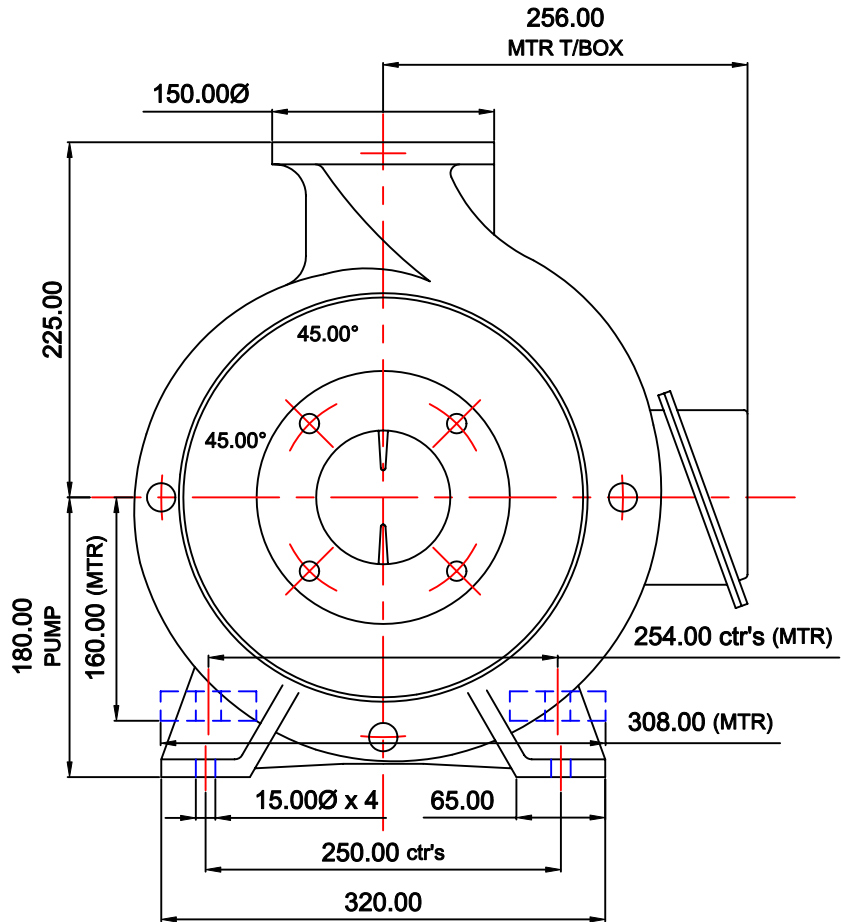

REVISION	THIS DATA REMAINS THE PROPERTY OF STALKER ENGINEERING. NO DATA MAY BE REPRODUCED WITHOUT PRIOR CONSENT OF COMPANY. DATA MAY BE ALTERED WITHOUT NOTIFICATION.
	AS1100 3rd ANGLE PROJECTION
	DO NOT SCALE

GENERAL TOLERANCES METRIC +/-0.400mm IMPERIAL +/-0.015"
REFERENCE: ORIG FILE REF. 28/06/2004
APPRVD:

DRWN: AR
DATE: UPDATED 20/07/2004
SCALE: DIAGRAMMATIC
FILE REF: REFER DWG NUMBER

STALKER PUMPS www.stalkerpumps.com.au
DIMENSION OUTLINE DIAGRAMMATIC ISO2858 65/40-250 CC SERIES 18.50kW 2P 160L (MODULE 2)
DRAWING No: 2900ISOCCEM016DIMA3

A3
